

← Arrow Antenna →

911 E. Fox Farm Rd. #2
Cheyenne, WY 82007

ArrowAntennas.com
Simply the Best

(307) 222-4712
info@arrowantennas.com

The OSJ VHF/Marine does **NOT** require a ground plane.

Ideal for mounting:

- In an attic
- On a roof vent pipe
- On a wooden (or Metal) pole
- On Fiberglass or Plastic Vehicles
(Motorhomes, Trucks, **Boats**)

Mount it just about anywhere.

SO-239 Feed Connector

Covers 152 - 162 MHz with a VSWR of less than 1.5:1.

Omni-Directional

The OSJ is a Heavy Duty Antenna. The elements are made from 3/8" solid aluminum with a heavy duty angle mounting bracket.

Nothing to tune. Nothing to adjust.

Covers 150 – 162 MHz.

Guarantee

No hassle refund

If you are not completely satisfied with any ARROW ANTENNA Product it can be returned for a FULL refund less shipping and handling within 90 DAYS of purchase date.

SIMPLY THE BEST

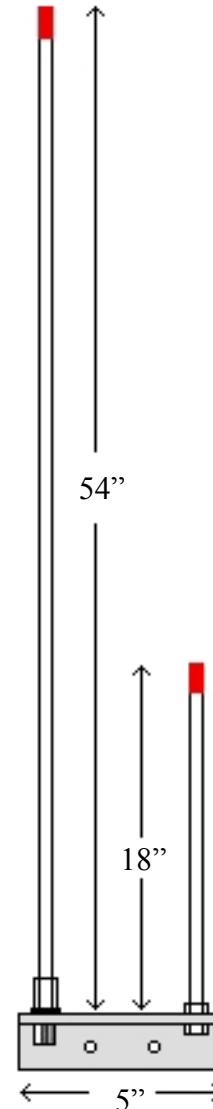

Model
OSJ VHF & Marine
Open Stub J-Pole

We don't invent antennas.
We simply build them better.

Part #	Price	Model OSJ VHF/Marine Parts List
OSJ01	\$14	3/8" X 54" Driven Element with Coupling Nut
OSJ02	\$12	3/8" X 18" Element with 2 Stainless Jam Nuts.
OSJ03	\$20	3/16" X 1 1/2" X 1 1/2" X 5" Assembly Bracket
52S206	\$4	Saddle Clamp for mounting to Mast up to 1 1/2" - (2 for \$4.)
J14605	\$4	SO-239 - 3/8-24 Antenna Mount
J14606	\$1	Nylon Shoulder Washer for Antenna Mount above - (2 for \$1.)
25C275	\$1	2 3/4" Bolt, Nut & Lock Washer (all Stainless)

(Please add \$8.00 S & H per order. Thank you.)

Assembly Instructions

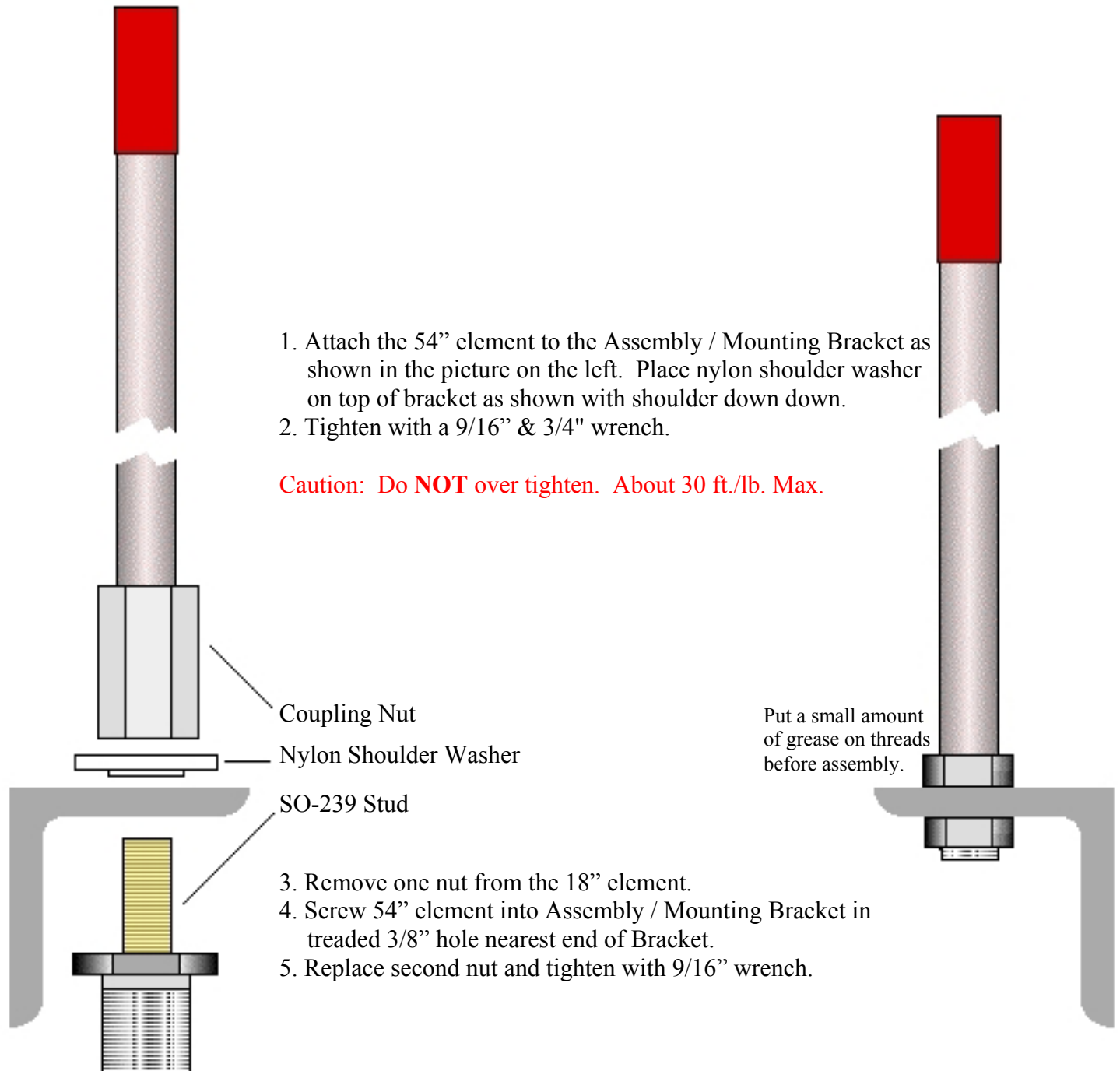

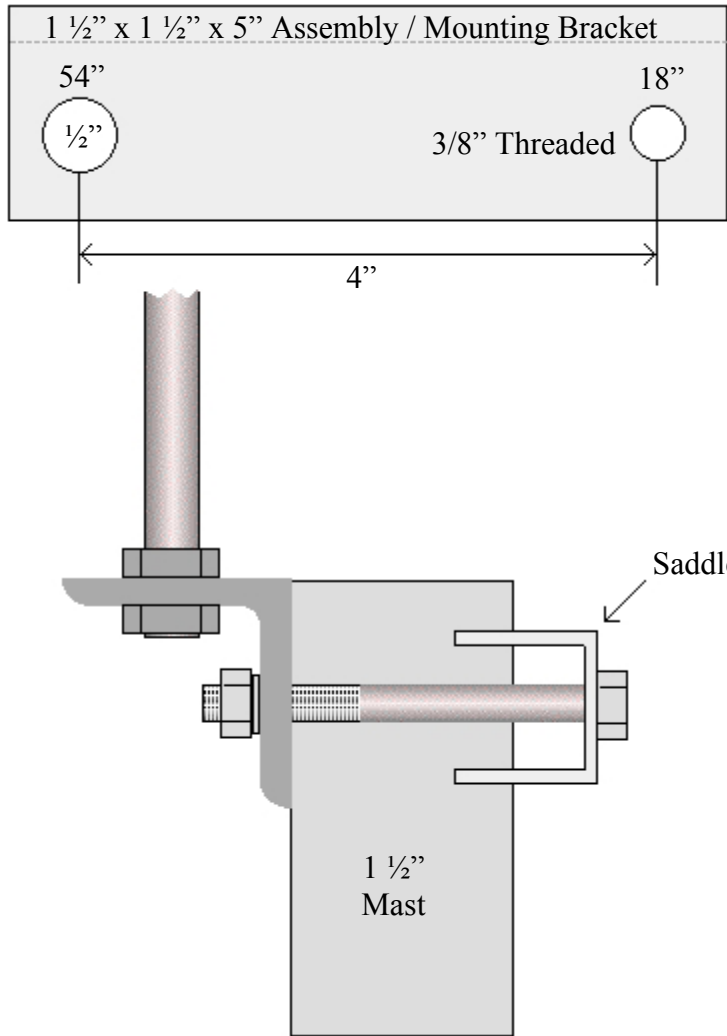

SWR Chart

of

Model OSJ VHF/Marine

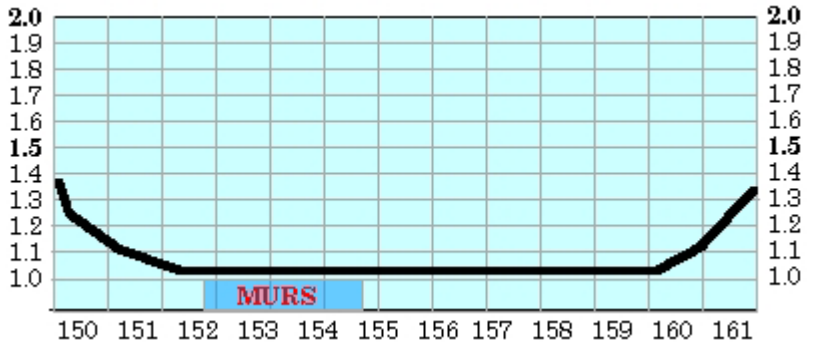

SWR

SWR is basically a way of testing the impedance of your Antenna System. The Antenna System has two parts.

1. Coax and connectors.
2. Antenna.

Before you can test or tune the Antenna, you have to test the other half of the system **first**, the Coax & Connectors.

Brand New Coax can be Defective or Damaged.

To test the Coax you will need a 50 ohm Dummy Load and an SWR Meter or Antenna Analyzer.

Note: Some of the MFJ 269 Analyzers don't work right. - - ([eHam reviews on the MFJ269](#)) - - The MJF 259B works Great.

Connect the Dummy Load to the end of the coax instead of the Antenna. Connect SWR Meter or Antenna Analyzer to the other end of the coax.

Check the SWR on all frequencies. SWR should be 1.0:1 on all frequencies. If the SWR is not 1.0:1 or if the SWR varies with frequency, then the Coax is **Not** up to the task.

Important: Some Coax can test fine on VHF but not at UHF.

Also a known problem with some remote Antenna Switches.

Example from eHam Reviews

I have had my MFJ269 for about 5 years. It works ok. On VHF and HF it is dead on. But on UHF I do not trust it. I also have a Bird and I compared several antennas tuned with the MFJ269 and the Bird and the MFJ269 was wrong everytime on the UHF side. I killed one UHF final when I relied on the MFJ269 for tuning. This antenna was checked with the Bird after the finals died and was found to have an SWR of 5:1+. Yet when checked with the MFJ269 it showed fine. I now use the Bird for everything but HF tuning. The MFJ269 still seems to work ok in this range and is nice for tuning my Buddy Pole for portable ops. It will never see VHF or UHF antennas again.

CHECKLIST FOR OUR SHIPPING DEPARTMENT
OSJ VHF/Marine

- 3/8" x 54" Driven Element with Coupling Nut
- 3/8" x 18" Element with 2 Stainless Jam Nuts.
- 3/16" x 1 1/2" x 1 1/2" x 5" Assembly Bracket

- Saddle Clamp
- SO-239 Stud & Nylon Shoulder Washer
- 2 @ 2 3/4" Bolts, Nuts & Lock Washers for saddle